



PNEUMATIC TOOLS

AVK PNEUMATIC TOOLS PROFILE

AVK has selected the **ARO Brand Pneumatic Tool** for its ergonomic design and outstanding dependability. The rocker style forward and reverse trigger is easy and comfortable to use.

The AVK pneumatic tool features a Quick-Change thread adaption kit. This patented* feature allows for easy access to the thread size component parts. AVK's Pneumatic tools provide the highest RPM for the thread size selected resulting in optimum installation speed.



THREAD ADAPTION KIT



*Patent No. 4,121,444

HOW THE AVK TOOL WORKS

- The operator quarter turns an AVK threaded insert onto the tool mandrel and places it into the hole in the parent material.
- The top trigger is depressed and the tool mandrel spins into the insert.
- The head of the threaded insert is gripped by the knurling at the nose piece preventing it from spinning as the threaded area of the insert "walks" up the mandrel.
- As this occurs, the AVK insert expands within the hole wall providing hole fill and then forms a secondary flange against the backside of the parent material.
- The tool continues to torque the insert's threads causing the knurling to bite into the backside edge of the parent material.
- The tool then stalls when it reaches its predetermined stall torque. This occurs even if the parent material varies in thickness. The tool needs no adjustment to install AVK's products in variable thickness materials.
- The operator then presses the lower reverse trigger and the mandrel spins out of the installed part.

DESIGN BENEFITS

- The AVK ARO tool uses torque to install the AVK product. It needs no adjustment to install the product in variable thickness material.
- The ergonomic design of the AVK ARO tool makes it feel comfortable to the operator and weighs in at 3 lbs. (1.36 kg).
- The rocker style trigger is easy to use & minimizes operator fatigue.
- The knurled nose assembly eliminates any torque "kick" during installation.
- Preventative maintenance is quick and easy with AVK's patented* quick-change thread adaption kit. No tools are required.
- The rugged design of the tool casing, its components and the AVK thread adaption kit provides you with reliability.

ADDITIONAL DESIGN TYPES

SPECIAL DESIGNS

AVK can design a thread adaption kit nose assembly to fit your particular application needs.



RIGHT ANGLE DESIGN

The Right Angle Inline Style Tool is designed for limited access applications.



INLINE DESIGN

The Inline Style Tool is designed for vertical installations.



HEAD FORMING THREAD ADAPTION KIT

A Head Forming T.A.K. is available to contour the AVK insert's head to the radius of a tube to increase torque capability.



AVK PNEUMATIC TOOL SPECIFICATIONS

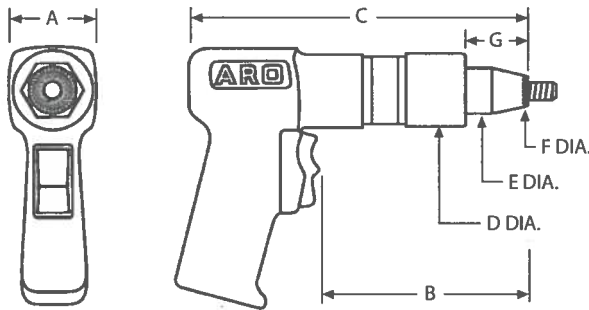

The tool shown on this page has been specifically designed to install the A-L, A-K, A-H, A-P and A-O Series Inserts.

Once you have selected the type of insert and thread size required for your application, select the appropriate RPM tool from the chart below.

DIMENSIONAL DATA / TOOL SET-UP REQUIREMENTS

RPM	WEIGHT LBS. (Kg)	A	B	C	D DIA.	E DIA.	F DIA. MAX.	G
3,000	2.55 (1.15)	1.86 (47,24)	4.75 (120,6)	7.75 (196,8)	1.57 (39,87)	1.00 (25,40)	.400 (10,16)	1.3 (33,0)
1,500	2.58 (1.17)	1.86 (47,24)	4.75 (120,6)	7.75 (196,8)	1.57 (39,87)	1.00 (25,40)	.400 (10,16)	1.3 (33,0)
900	3.18 (1.44)	1.86 (47,24)	6.00 (152,4)	9.00 (228,6)	1.57 (39,87)	1.00 (25,40)	.500 (12,7)	1.3 (33,0)
600	3.18 (1.44)	1.86 (47,24)	6.00 (152,4)	9.00 (228,6)	1.57 (39,87)	1.00 (25,40)	.640 (16,25)	1.3 (33,0)
350	3.25 (1.46)	1.86 (47,24)	5.37 (136,3)	8.37 (212,5)	1.50 (38,10)	1.42 (36,06)	.900 (22,86)	NA (NA)

PROPER AIR SUPPLY SET-UP REQUIRES:

- 90-110 PSI (6.2-7.5 BARS) dynamic (tool running) air pressure at 25 S.C.F.M.
- Inline oiler/separator
- Air pressure gauge and regulator
- 5/16 or 7/92 mm minimum hose ID
- 5/16 or 7/92 mm minimum fittings ID

SPECIAL FEATURE—The AKPT nose cone design incorporates a special pilot/serrated tip that is essential to proper insert installation. The "A-K" prefix in the tool part number designates this feature



AIR TOOL SELECTION / SPARE PARTS

THREAD SIZE	TOOL R.P.M	COMPLETE TOOL PART NUMBER	THREAD ADAPTION KIT	A HEX DRIVE	B MANDREL 10 PER BAG	C BEARING SET	D NOSE CONE	DYNAMIC AIR PRESSURE SETTINGS PSI - BARS
6-32 UNC	3000	AKPT30P632	AKPT632TAK	29NPT22	83SH632-1500	32PT1	77AKPT6	70 - 80
8-32 UNC	3000	AKPT30P832	AKPT832TAK	29NPT23	83SH832-1500	32PT2	77AKPT8	75 - 90
10-24 UNC	1500	AKPT15P1024	AKPT1024TAK	29NPT4	83SH1024-1750	32PT4	77AKPT10	60 - 80
10-32 UNF	1500	AKPT15P1032	AKPT1032TAK	29NPT4	83SH1032-1750	32PT4	77AKPT10	60 - 80
1/4-20 UNC	900	AKPT9P420	AKPT420TAK	29NPT5	83SH420-1500	32PT5	77AKPT250	70 - 90
5/16-18 UNC	600	AKPT6P518	AKPT518TAK	29NPT6	83SH518-2000	32PT7	77AKPT3125	80 - 110
3/8-16 UNC	600	AKPT6P616	AKPT616TAK	29NPT7	83SH616-2000	32PT8	77AKPT375	80 - 110
1/2-13 UNC	350	AKPT3P813	AKPT813CTA	29NPT26	83SH813-2500	30NPT500	77AKPT500	80 - 110
M4 x 0,7 ISO	3000	AKPT30P470	AKPT470TAK	29NPT24	83SH470-40	32PT3	77AKPT470	4.8 - 5.5
M5 x 0,8 ISO	1500	AKPT15P580	AKPT580TAK	29NPT10	83SH580-45	32PT4	77AKPT580	4.1 - 5.5
M6 x 1,0 ISO	900	AKPT9P610	AKPT610TAK	29NPT11	83SH610-40	32PT6	77AKPT610	4.8 - 6.2
M8 x 1,25 ISO	600	AKPT6P8125	AKPT8125TAK	29NPT12	83SH8125-50	32PT7	77AKPT8125	5.5 - 7.5
M10 x 1,50 ISO	600	AKPT6P1015	AKPT1015TAK	29NPT25	83SH1015-50	32PT10	77AKPT1015	5.5 - 7.5
M12 x 1,75 ISO	350	AKPT3P12175	AKPT12175CTA	29NPT27	83SH12175-60	30NPT500	77AKPT12175	5.5 - 7.5

This chart designates the tool, spare parts and dynamic (tool running) air pressure requirements for our most popular steel product. Consult the AVK tool catalog or contact an AVK Sales Representative for tool RPM and air pressure settings for aluminum, brass and monel product.

NOTE: UNF FINE THREAD COMPONENTS ARE AVAILABLE.

PREVENTATIVE MAINTENANCE REQUIREMENTS:

- The bearing set must be kept in a WET lubricated condition to assure proper tool operation. AVK suggests the use of high temperature grease such as LUBRIPLATE™ BRAND 930 AA.
- The tool mandrel should be inspected for thread wear or damage and replaced. To test the condition of the mandrel, thread an AVK insert onto the mandrel backwards until it touches the pilot. If any drag is still felt, replace the mandrel with a new socket head cap screw.



PNEUMATIC TOOLS

AVK PNEUMATIC TOOL SPECIFICATIONS

The tool shown on this page has been specifically designed to install the A-T, A-W, E-L and E-H Series Inserts.

Once you have selected the type of insert and thread size required for your application, select the appropriate RPM tool from the chart below.

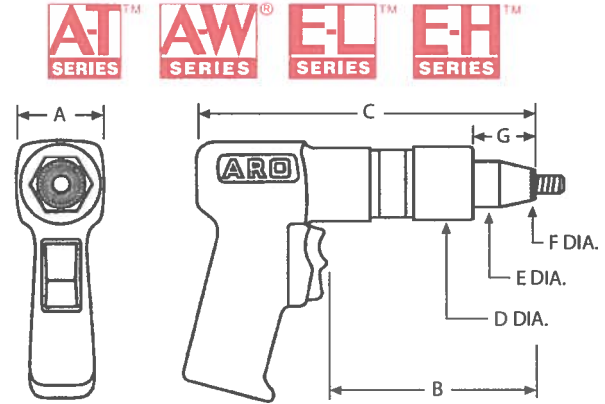

DIMENSIONAL DATA / TOOL SET-UP REQUIREMENTS

PROPER AIR SUPPLY SET-UP REQUIRES:

- 90-110 PSI (6.2-7.5 BARS) dynamic (tool running) air pressure at 25 S.C.F.M.
- Inline oiler/separator
- Air pressure gauge and regulator
- 5/16 or 7,92 mm minimum hose ID
- 5/16 or 7,92 mm minimum fittings ID

RPM	WEIGHT LBS. (Kg)	A	B	C	D DIA.	E DIA.	F DIA. MAX.	G
3,000	2.55 (1.15)	1.86 (47,24)	4.75 (120,6)	7.75 (196,8)	1.57 (39,87)	1.00 (25,40)	.350 (8,89)	1.3 (33,0)
1,500	2.58 (1.17)	1.86 (47,24)	4.75 (120,6)	7.75 (196,8)	1.57 (39,87)	1.00 (25,40)	.600 (15,24)	1.3 (33,0)
600	3.18 (1.44)	1.86 (47,24)	6.00 (152,4)	9.00 (228,6)	1.57 (39,87)	1.00 (25,40)	.625 (15,87)	1.3 (33,0)
350	3.25 (1.46)	1.86 (47,24)	6.00 (152,4)	8.37 (212,5)	1.50 (38,10)	1.43 (36,32)	.900 (22,86)	NA (NA)

SPECIAL FEATURE—The NPT nose cone design incorporates a special serrated tip that is essential to proper insert installation. The "N" prefix in the tool part no. designates this feature.

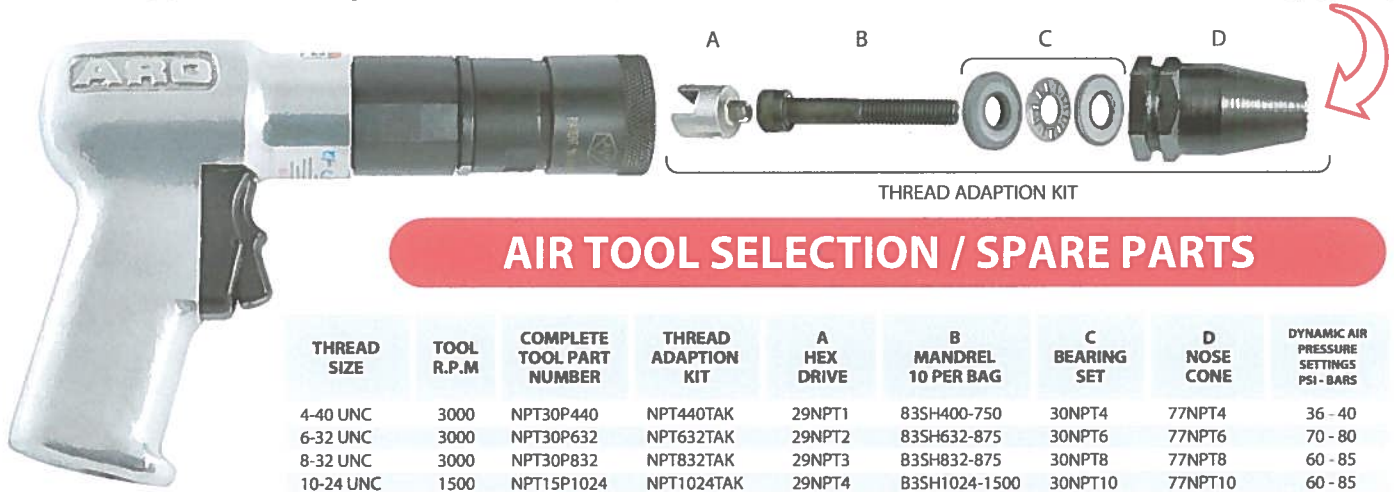

AIR TOOL SELECTION / SPARE PARTS

THREAD SIZE	TOOL R.P.M	COMPLETE TOOL PART NUMBER	THREAD ADAPTION KIT	A HEX DRIVE	B MANDREL 10 PER BAG	C BEARING SET	D NOSE CONE	DYNAMIC AIR PRESSURE SETTINGS PSI - BARS
4-40 UNC	3000	NPT30P440	NPT440TAK	29NPT1	83SH400-750	30NPT4	77NPT4	36 - 40
6-32 UNC	3000	NPT30P632	NPT632TAK	29NPT2	83SH632-875	30NPT6	77NPT6	70 - 80
8-32 UNC	3000	NPT30P832	NPT832TAK	29NPT3	83SH832-875	30NPT8	77NPT8	60 - 85
10-24 UNC	1500	NPT15P1024	NPT1024TAK	29NPT4	83SH1024-1500	30NPT10	77NPT10	60 - 85
10-32 UNF	1500	NPT15P1032	NPT1032TAK	29NPT4	83SH1032-1500	30NPT10	77NPT10	60 - 85
1/4-20 UNC	1500	NPT15P420	NPT420TAK	29NPT5	83SH420-1250	30NPT250	77NPT250	70 - 95
5/16-18 UNC	600	NPT6P518	NPT518TAK	29NPT6	83SH518-1750	30NPT3125	77NPT3125	80 - 100
3/8-16 UNC	600	NPT6P616	NPT616TAK	29NPT7	83SH616-1750	30NPT375	77NPT375	90 - 110
1/2-13 UNC	350	NPT3P813	NPT813CTA	29NPT26	83SH813-2000	30NPT500	77NPT500	95 - 110
M3 x 0,5 ISO	3000	NPT30P350	NPT350TAK	29NPT8	83SH350-20	30NPTM3	77NPTM3	2.4 - 2.7
M4 x 0,7 ISO	3000	NPT30P470	NPT470TAK	29NPT9	83SH470-20	30NPTM4	77NPTM4	4.1 - 5.5
M5 x 0,8 ISO	1500	NPT15P580	NPT580TAK	29NPT10	83SH580-40	30NPTM5	77NPTM5	4.1 - 5.5
M6 x 1,0 ISO	1500	NPT15P610	NPT610TAK	29NPT11	83SH610-35	30NPTM6	77NPTM6	4.8 - 6.5
M8 x 1,25 ISO	600	NPT6P8125	NPT8125TAK	29NPT12	83SH8125-45	30NPTM8	77NPTM8	5.5 - 6.8
M10 x 1,50 ISO	600	NPT6P1015	NPT1015TAK	29NPT25	83SH1015-45	32PT10	77NPT1015	6.2 - 7.5
M12 x 1,75 ISO	350	NPT3P12175	NPT12175CTA	29NPT27	83SH12175-50	30NPT500	77NPTM12	6.2 - 7.5

This chart designates the tool, spare parts and dynamic (tool running) air pressure requirements for our most popular steel product. Consult the AVK tool catalog or contact an AVK Sales Representative for tool RPM and air pressure settings for aluminum, brass and stainless product.

NOTE: UNF FINE THREAD COMPONENTS ARE AVAILABLE.
PREVENTATIVE MAINTENANCE REQUIREMENTS:

- The bearing set must be kept in a WET lubricated condition to assure proper tool operation. AVK suggests the use of high temperature grease such as LUBRIPLATE® BRAND 930 AA.
- The tool mandrel should be inspected for thread wear or damage and replaced. To test the condition of the mandrel, thread an AVK insert onto the mandrel backwards until it touches the knurled nose cone. If any drag is still felt, replace the mandrel with a new socket head cap screw.

AVK PNEUMATIC TOOL SPECIFICATIONS



PNEUMATIC TOOLS

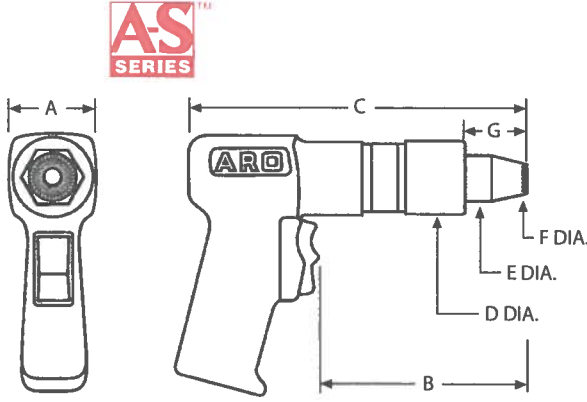

The tool shown on this page has been specifically designed to install the A-S Series Stud.

Once you have selected the type of stud and thread size required for your application, refer to the chart below for air tool selection.

DIMENSIONAL DATA / TOOL SET-UP REQUIREMENTS

RPM	WEIGHT LBS. (Kg)	A	B	C	D DIA.	E DIA.	F DIA. MAX.	G
3,000	2.55 (1.15)	1.86 (47,24)	4.75 (120,6)	7.75 (196,85)	1.57 (39,87)	1.00 (25,40)	.400 (10,16)	1.3 (33,0)
1,500	2.58 (1.17)	1.86 (47,24)	4.75 (120,6)	7.75 (196,85)	1.57 (39,87)	1.00 (25,40)	.400 (10,16)	1.3 (33,0)
900	3.18 (1.44)	1.86 (47,24)	6.00 (152,4)	9.00 (228,6)	1.57 (39,87)	1.00 (25,40)	.500 (12,7)	1.3 (33,0)
600	3.18 (1.44)	1.86 (47,24)	6.00 (152,4)	8.37 (212,6)	1.57 (39,87)	1.00 (25,40)	.640 (16,25)	1.3 (33,0)

PROPER AIR SUPPLY SET-UP REQUIRES:

- 90-110 PSI (6.2-7.5 BARS) dynamic (tool running) air pressure at 25 S.C.F.M.
- Inline oiler/separator
- Air pressure gauge and regulator
- 5/16 or 7,92 mm minimum hose ID
- 5/16 or 7,92 mm minimum fittings ID

SPECIAL FEATURE—This tool nose cone design incorporates a special serrated tip that is essential to proper installation.

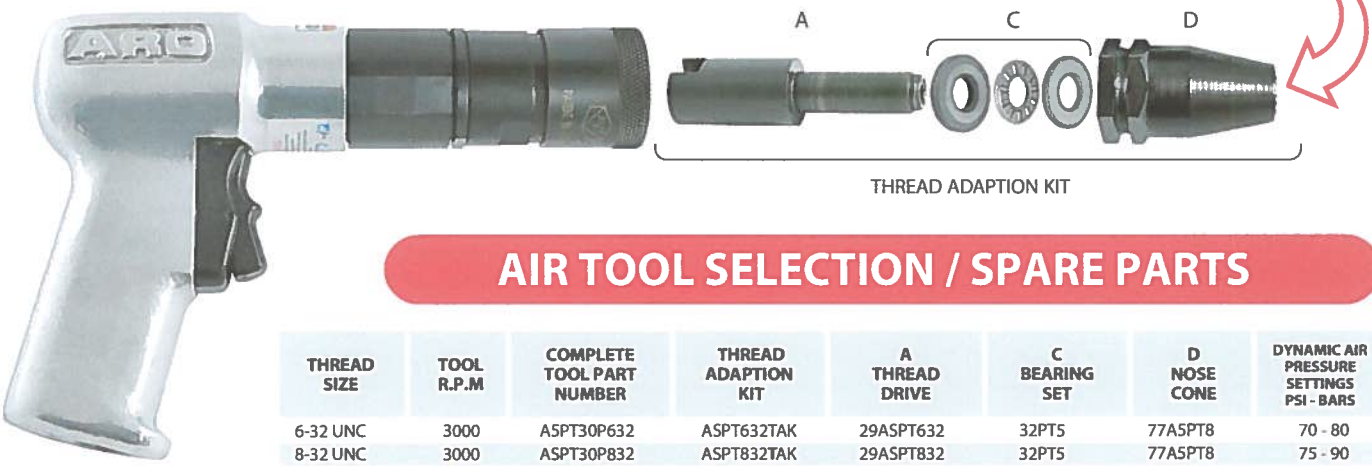

AIR TOOL SELECTION / SPARE PARTS

THREAD SIZE	TOOL R.P.M.	COMPLETE TOOL PART NUMBER	THREAD ADAPTION KIT	A THREAD DRIVE	C BEARING SET	D NOSE CONE	DYNAMIC AIR PRESSURE SETTINGS PSI - BARS
6-32 UNC	3000	ASPT30P632	ASPT632TAK	29ASPT632	32PT5	77A5PT8	70 - 80
8-32 UNC	3000	ASPT30P832	ASPT832TAK	29ASPT832	32PT5	77A5PT8	75 - 90
10-24 UNC	1500	ASPT15P1024	ASPT1024TAK	29ASPT1024	32PT12	77ASPT10	60 - 80
10-32 UNF	1500	ASPT15P1032	ASPT1032TAK	29ASPT1032	32PT12	77ASPT10	60 - 80
1/4-20 UNC	900	ASPT9P420	ASPT420TAK	29ASPT420	32PT8	77ASPT4	70 - 90
5/16-18 UNC	600	ASPT6P518	ASPT518CTA	29ASPT518	30NPT500	77A5PT8125	80 - 110
3/8-16 UNC	600	ASPT6P616	ASPT616CTA	29ASPT616	30NPT500	77A5PT8125	80 - 110
M4 x 0,7 ISO	3000	ASPT30P470	ASPT470TAK	29ASPT470	32PT5	77ASPT8	4.8 - 5.5
M5 x 0,8 ISO	1500	ASPT15P580	ASPT580TAK	29ASPT580	32PT12	77ASPT10	4.1 - 5.5
M6 x 1,0 ISO	900	ASPT9P610	ASPT610TAK	29ASPT610	32PT8	77ASPT4	5.5 - 6.2
M8 x 1,25 ISO	600	ASPT6P8125	ASPT8125CTA	29ASPT8125	30NPT500	77ASPT8125	5.5 - 7.5
M10 x 1,50 ISO	600	ASPT6P1015	ASPT1015CTA	29ASPT1015	30NPT500	77ASPT8125	5.5 - 7.5

NOTE: Air pressure settings are specified dynamic (tool running).

PREVENTATIVE MAINTENANCE REQUIREMENTS:

- The bearing set must be kept in a WET lubricated condition to assure proper tool operation. AVK suggests the use of high temperature grease such as LUBRIPLATE® BRAND 930 AA.



PNEUMATIC TOOLS

AVK PNEUMATIC TOOL SPECIFICATIONS

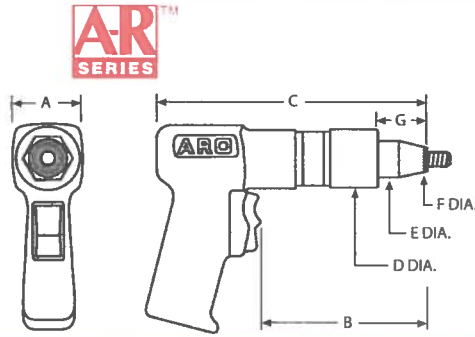

The tool shown on this page has been specifically designed to install the A-R Series Inserts.

AVK recommends that trial installations be performed to determine the optimum tool for the fastener selected using actual application materials and hole sizes. Tool RPM and parent material density will affect the grip range of the fastener. See the chart below for guidelines.

DIMENSIONAL DATA / TOOL SET-UP REQUIREMENTS

PROPER AIR SUPPLY SET-UP REQUIRES:

- 90-110 PSI (6.2-7.5 BARS) dynamic (tool running) air pressure at 25 S.C.F.M.
- Inline oiler/separator
- Air pressure gauge and regulator
- 5/16 or 7,92 mm minimum hose ID
- 5/16 or 7,92 mm minimum fittings ID

RPM	WEIGHT LBS. (Kg)	A	B	C	D DIA.	E DIA.	F DIA. MAX.	G
1,500	2.58 (1.17)	1.86 (47,24)	4.75 (120,6)	7.75 (196,8)	1.57 (39,87)	1.00 (25,40)	.400 (10,16)	1.3 (33,0)
900	3.18 (1.44)	1.86 (47,24)	6.00 (152,4)	9.00 (228,6)	1.57 (39,87)	1.00 (25,40)	.500 (12,70)	1.3 (33,0)

SPECIAL FEATURE—The NPT nose cone design incorporates a special serrated tip that is essential to proper insert installation. The "N" prefix in the tool part number designates this feature.

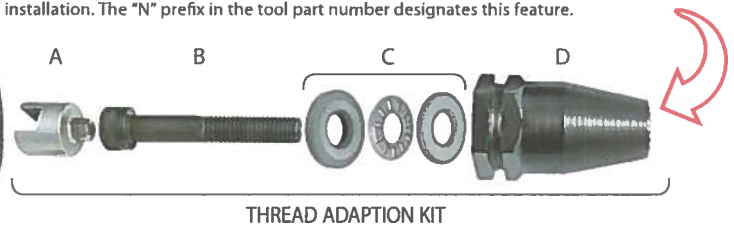
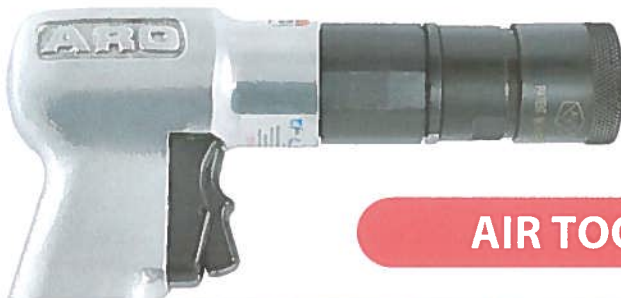

AIR TOOL SELECTION / SPARE PARTS

AVK PART NUMBER	TOOL R.P.M	PARENT MATERIAL		COMPLETE TOOL PART NUMBER	THREAD ADAPTION KIT	A HEX DRIVE	B SCREW MANDREL	C BEARING SET	D NOSE CONE	DYNAMIC AIR PRESSURE SETTINGS PSI - BARS
		STEEL, ALUMINUM FIBERGLASS SML GRIP RANGE	BLOW, ROTATIONAL SOFT PLASTICS GRIP RANGE							
ARS4-420-280	1500	.020 - .190	.020 - .250	ARPT15P420-280	ARPT420-280TAK	29NPT5	35H420-2000	32PT5	77NPT250	60 - 70
	900	.020 - .250	.020 - .250	ARPT9P420-280						40 - 60
ARS4-420-500	1500	.250 - .430	.250 - .470	ARPT15P420-500	ARPT420-500TAK	29NPT5	35H420-2250	32PT5	77NPT250	60 - 70
	900	.250 - .470	.250 - .470	ARPT9P420-500						40 - 60
ARS4-518-280	900	.020 - .260	-	ARPT9P518-280	ARPT518-280TAK	29NPT6	35H518-2500	32PT12	77NPT3125	70 - 90
	-	-	-	-						-
ARS4-518-500	900	.280 - .480	-	ARPT9P518-500	ARPT518-500TAK	29NPT6	35H518-2750	32PT12	77NPT3125	70 - 90
	-	-	-	-						-
ARS4-616-280	600	.020 - .260	-	ARPT6P616-280	ARPT616-280TAK	29NPT7	35H616-2500	32PT8	77NPT375	70 - 90
	-	-	-	-						-
ARS4-610-7.1	1500	0.5 - 4.8	0.5 - 6.3	ARPT15P610-7.1	ARPT610-7.1TAK	29NPT11	35H610-50	32PT6	77NPTM6	4.1 - 4.8
	900	0.5 - 6.3	0.5 - 6.3	ARPT9P610-7.1						2.8 - 4.1
ARS4-610-12.7	1500	6.3 - 10.9	6.3 - 11.9	ARPT15P610-12.7	ARPT610-12.7TAK	29NPT11	35H610-55	32PT6	77NPTM6	4.1 - 4.8
	900	6.3 - 11.9	6.3 - 11.9	ARPT9P610-12.7						2.8 - 4.1
ARS4-8125-7.1	900	0.5 - 6.6	0.5 - 6.6	ARPT9P8125-7.1	ARPT8125-7.1TAK	29NPT12	35H8125-60	32PT7	77NPTM8	4.8 - 6.2
	-	-	-	-						-
ARS4-8125-12.7	900	7.1 - 12.2	-	ARPT9P8125-12.7	ARPT8125-12.7TAK	29NPT12	35H8125-65	32PT7	77NPTM8	4.8 - 6.2
	-	-	-	-						-
ARS4-1015-7.1	600	0.5 - 6.6	-	ARPT6P1015-7.1	ARPT1015-7.1TAK	29NPT25	35H1015-60	32PT10	77NPT1015	4.8 - 6.2
	-	-	-	-						-

This chart designates the tool, spare parts and dynamic (tool running) air pressure requirements for our most popular steel product.

NOTE: UNF FINE THREAD COMPONENTS ARE AVAILABLE.

PREVENTATIVE MAINTENANCE REQUIREMENTS:

- The bearing set must be kept in a WET lubricated condition to assure proper tool operation. AVK suggests the use of high temperature grease such as LUBRIPLATE® BRAND 930 AA.
- The tool mandrel should be inspected for thread wear or damage and replaced. To test the condition of the mandrel, thread an AVK insert onto the mandrel backwards until it touches the pilot. If any drag is still felt, replace the mandrel with a new socket head cap screw.