

- NOTES:
- 1) MATERIAL: CH = 4037 STEEL
FINISH: CAD PLATE per QQ-P-416 CL 2 TY
TENSILE: 85,000 p.s.i MIN.
 - 2) FOR INSTALLATION TOOLS C-302 & C-845
SPECIAL PULL-UP STUD (60-1000-1032L)
MUST BE USED

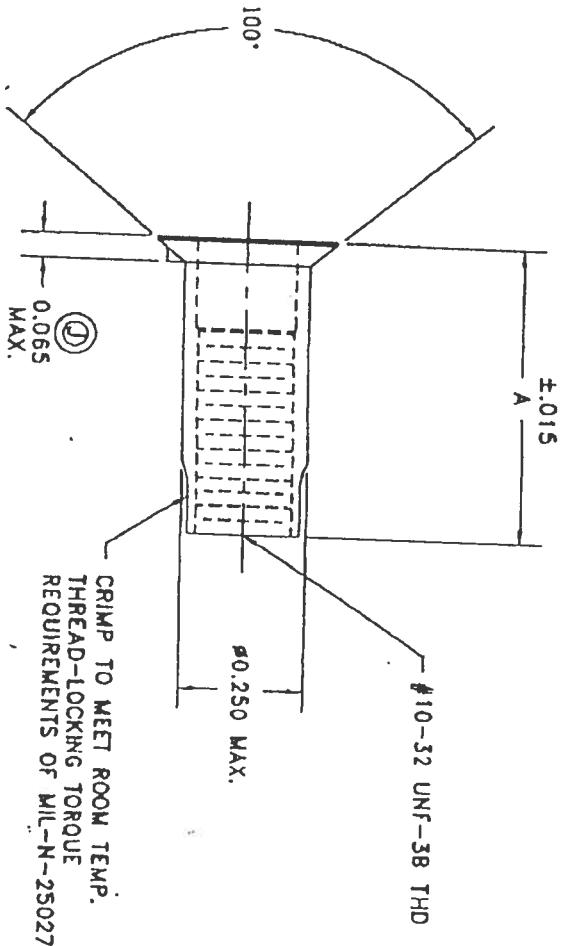
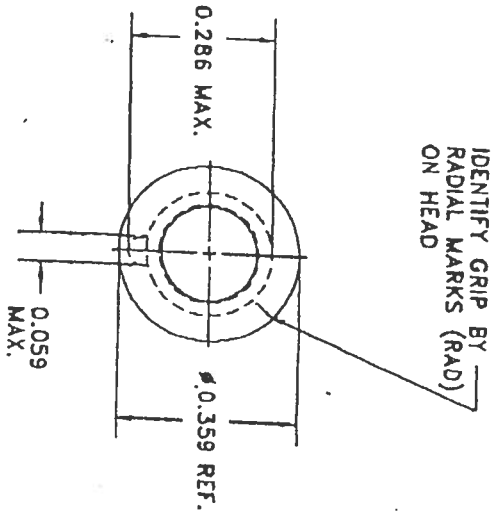

PART NO.	IDENT.	GRIP RANGE	A
2R1394	BLANK	.050 -.101	.563
2R1394-1	1 RAD	.101 -.151	.612
2R1394-2	2 RAD	.151 -.201	.673

RIVNUT® Engineered Products

SYM	ECN NO.	DESCRIPTION	BY	APP	DATE	TITLE
F	1113	AMERICAN PART NO. 2705-1	J	J	4/7/95	#10-32 SELF-LOCKING
G	2655	CHANGES MADE TO THE ORIGINAL DESIGN	J	J	4/7/95	SPECIAL 100° CRIMP HEAD
H	2908	CHANGES MADE TO THE ORIGINAL DESIGN	J	J	4/7/95	(HIGH STRENGTH)
J	3057	CHANGES MADE TO THE ORIGINAL DESIGN	J	J	4/7/95	

2705 Meriton Drive, Kendallville, IN 46755 PH(219)347-3803 FAX(219)347-3928

DWG. NO. **C2R1394** REV. **J**

1 of 1