

RIVNUT® PLUSNUT® Pre-Bulbed

The PLUSNUT® Pre-Bulbed has been designed to be installed using torque controlled hand or power tools. A simple torque hand tool (shown on page 28) can be packaged with this fastener for customer installation. Use of the C302 power tool (shown on page 27) can install this fastener in variable thickness plastic materials such as those produced by rotational or blow molding. A grip ID mark is included on the head of the fastener for grip range identification.

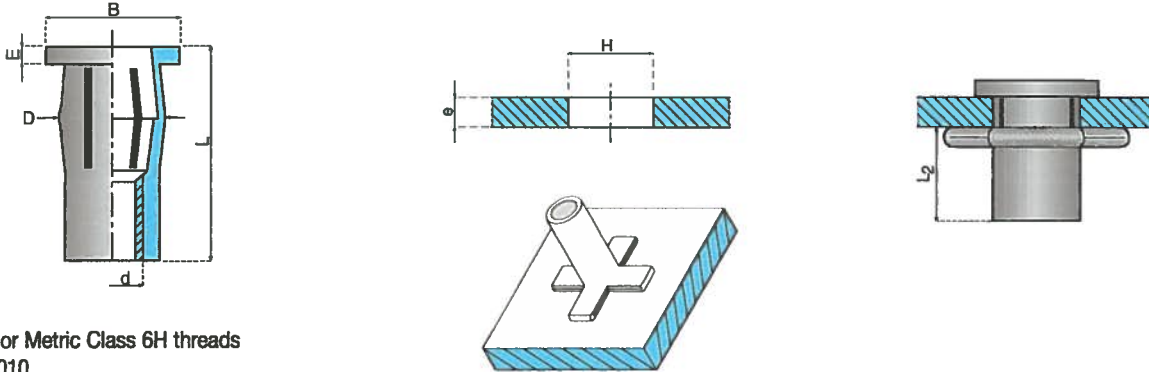

Class 2B or Metric Class 6H threads
Steel: C1010

d Thread Size	e Grip Range	H Hole Size		D Body Diameter	E Head Height	B Head Diameter	L Overall Length	L ₂ Installed Length	Grip ID Mark	Product Code
		Min.	Max.							

All Dimensions Shown In Inches

10-32	0.020-0.175	0.312	0.317	0.310	0.038	0.500	0.80	0.425		S10PB175
10-32	0.175-0.320	0.312	0.317	0.310	0.038	0.500	0.94	0.425	1 RAD	S10PB320
1/4-20	0.020-0.280	0.386	0.391	0.384	0.058	0.625	1.03	0.505		S25PB280
1/4-20	0.280-0.500	0.386	0.391	0.384	0.058	0.625	1.26	0.505	1 RAD	S25PB500
5/16-18	0.020-0.280	0.484	0.489	0.482	0.062	0.750	1.18	0.570		S31PB280
5/16-18	0.280-0.500	0.484	0.489	0.482	0.062	0.750	1.41	0.570	1 RAD	S31PB500
3/8-16	0.020-0.280	0.562	0.569	0.560	0.088	0.875	1.27	0.605		S37PB280
3/8-16	0.280-0.500	0.562	0.569	0.560	0.088	0.875	1.49	0.605	1 RAD	S37PB500

All Dimensions Shown In Millimeters

M6x1.0	0.50-7.10	9.80	9.93	9.76	1.50	15.9	26.2	12.8		SM6PB7.10
M6x1.0	7.10-12.70	9.80	9.93	9.76	1.50	15.9	32.0	12.8	1 RAD	SM6PB12.70
M8x1.25	0.50-7.10	12.29	12.42	12.25	1.57	19.0	30.0	14.5		SM8PB7.10
M8x1.25	7.10-12.70	12.29	12.42	12.25	1.57	19.0	35.8	14.5	1 RAD	SM8PB12.70
M10x1.50	0.50-7.10	14.27	14.45	14.23	2.24	22.2	32.3	15.4		SM10PB7.10
M10x1.50	7.10-12.70	14.27	14.45	14.23	2.24	22.2	37.8	15.4	1 RAD	SM10PB12.70

Note 1: The product on this page is made from Steel ("S" prefix in product code) with Cadmium plating. It is also available in Stainless Steel ("SS" for the prefix) or Aluminum ("A" for the prefix).

Note 2: Countersunk head, finishes or design variations are available upon request.